

Date	Drawn Rys.	App'd Zatr.	Revision	Revision Rewizja	No. Nr.	Mark. Oznac.

When casting screen tubes make workjoint every 600mm

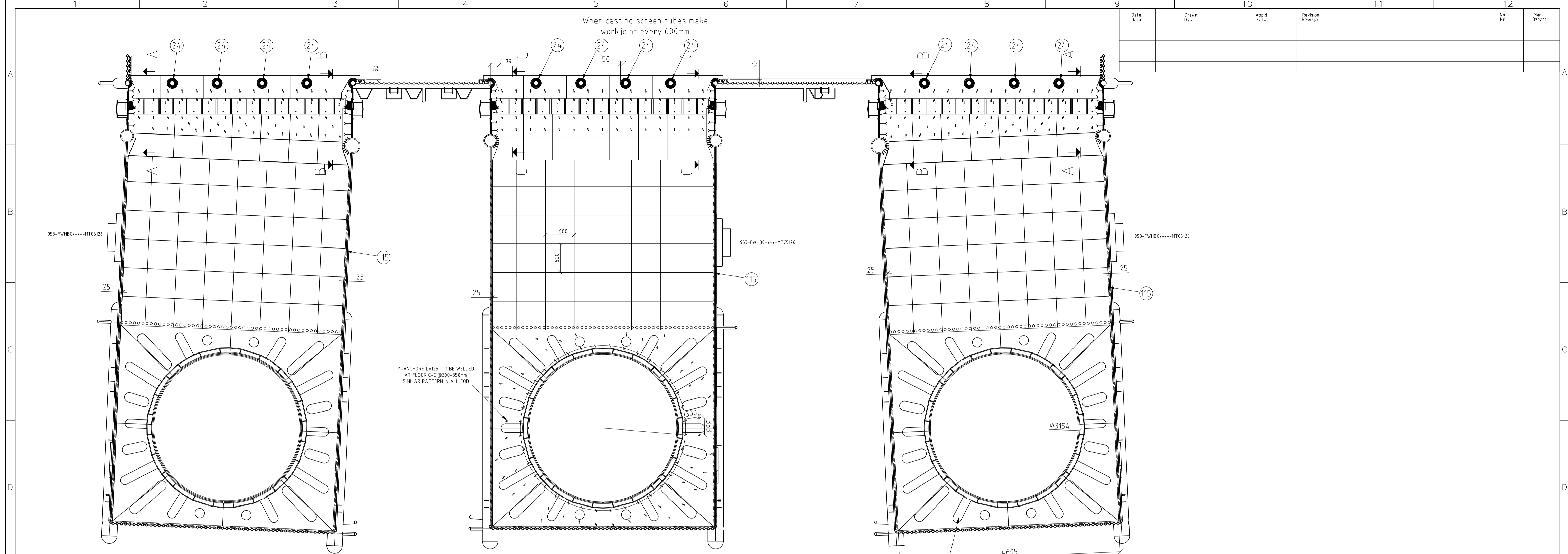

Y-ANCHORS L=125 TO BE WELDED AT FLOOR C-C @300-350mm SIMILAR PATTERN IN ALL COG

Before casting of floor in Cross Over duct!
Weld hexmesh net across the openings in the steelplate to prevent castable from falling thru.
However -weld the net AFTER casting around Vortex Finder!

DETAIL OF EXP JOINTS FILLED WITH FIBER SEE DWG 953-FWHBC...-MTC5130

MAX WIDTH OF PANELS IS APPROX 2.4M
FINAL PLACEMENT OF WORKJOINTS TO BE DETERMINATED AT SITE

THIS DRAWING IS CONNECTED WITH
953-FWHBC...-MTC5116
953-FWHBC...-MTC5121
953-FWHBC...-MTC5130

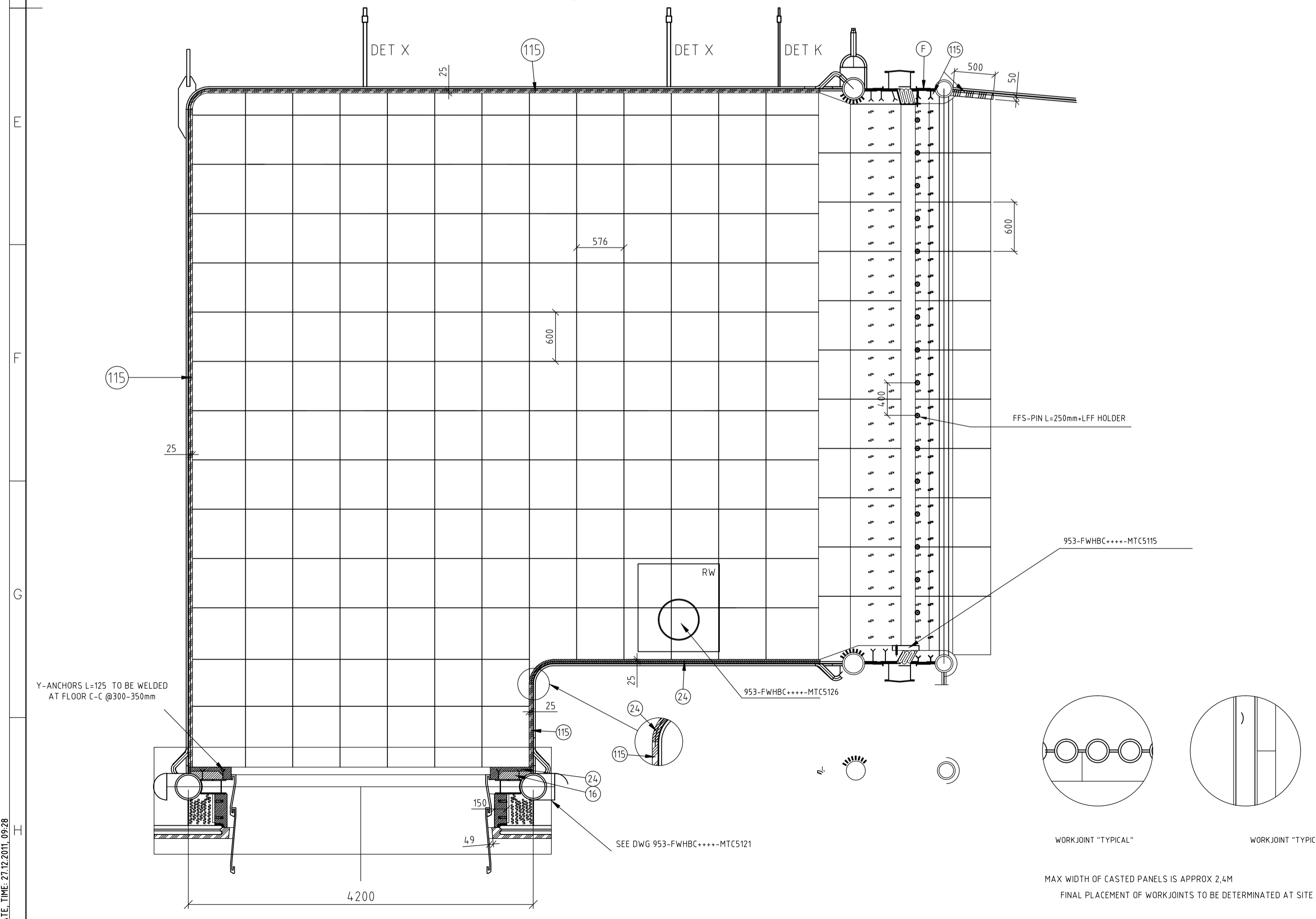

WORKJOINT "TYPICAL"

WORKJOINT "TYPICAL"

MAX WIDTH OF CASTED PANELS IS APPROX 2.4M
FINAL PLACEMENT OF WORKJOINTS TO BE DETERMINATED AT SITE

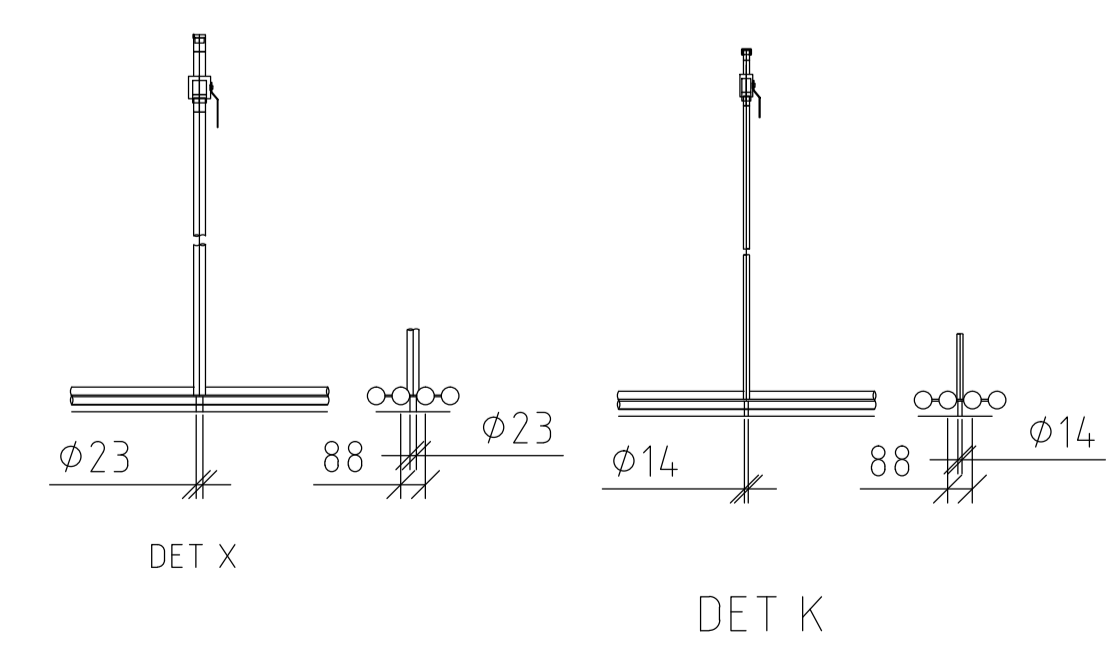

THIS DOCUMENT AND ANY INFORMATION HEREIN CONTAINED ARE THE PROPERTY OF FOSTER WHEELER CORPORATION. THE UNAUTHORIZED COPYING BY, USE BY, OR DISCLOSURE TO PERSONS WHO ARE NOT ENTITLED TO RECEIPT OF SUCH DISCLOSURE, OR DISCLOSURE TO PERSONS WHO ARE LIKELY TO MISUSE THIS DOCUMENT OR INFORMATION, IS PROHIBITED. ANY BREACH AGAINST THE ABOVE PROHIBITION IS LIABLE TO ENFORCEMENT, WITH DAMAGES PAYABLE TO THOSE AGGRIEVED AND OTHER REMEDIES AVAILABLE BY LAW OR EQUITY.
TEN DOKUMENT INFORMACJE W NIM ZAWARTE SA WŁASNOŚCIĄ KORPORACJI FOSTER WHEELER. NIELEGALNE KOPLOWANIE, UŻYTKOWANIE LUB UJAWNIANIE OSOBOM NIEUPRAWNIWIONYM LUB UJAWNIANIE OSOBOM, KTÓRE PRAWOPODOBNIENIE NIEWŁASCIWIE ZASTOSUJĄ TEN DOKUMENT LUB INFORMACJE W NIM ZAWARTE JEST ZAKAZANE. ZŁAMANIE POWYŻSZYCH ZAKAZÓW PODLEGA USTAWOWO WPLACIE KARNEGO ODSTRZEGOWANIA LUB NARAŻA UŻYTKOWNIKA NA ZASTOSOWANIE INNEGO SPOSOBU KARANIA PRZEWIDZIANEGO PRZEZ PRAWO I SPRAWIEDLIWOŚĆ.

FINAL WERSJA FINALNA

F	INSULATION FIBER	
Y175	Y-ANCHOR L=175 Quality Z53 MA	
Y150	Y-ANCHOR L=150 Quality Z53 MA	
Y125	Y-ANCHOR L=125 Quality Z53 MA	
Y100	Y-ANCHOR L=100 Quality Z53 MA	
115	CALDE GUN LM 74 A	
24	CALDE FLOW LF 50 A	
16	CALDE CAST XL 106 C/G	

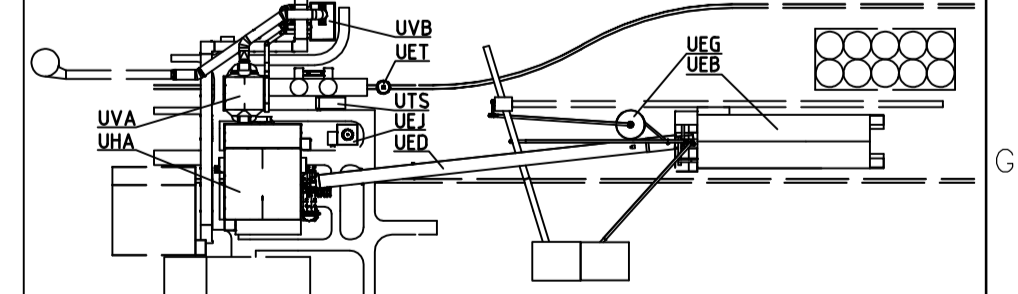

LEGEND / LEGENDA
UVA BOILER HOUSE / KOTŁOWNIA UUB CONVEYOR / PRZENOŚNIK
UVA ELECTRICAL PRECIPITATOR / ELEKTROFILTR UUA AMMONIA TANK / ZBIORNIK AMONIAKU
UUB ID-FAN ROOM / POMIESZCZENIE WENTYLATORA SPALIN UUE FLYASH SLO / SIŁOS POPIOŁU LOTNEGO
UUA BARN / MAGAZYN UUG AGRO-SILO / ZBIORNIK BIOMASY

Client Klient	GDF SUEZ Energia Polska S.A.		
Project Projekt	Polaniec Green Unit		
Main Assembly Nazwa Projektu	CFB 158.3/135.1 kg/s, 127.5/19.5 bar, 535/535 °C		
Title Tytuł rys.	COD		
Dwg size Wielkość rys.	A1	Date Data	12.09.2011
Designed Konstruował	Jörn	Work No. Nr pracy	12.09.2011
Sub Checked Pobr. Sprawdził		Scale Skala	1:40 1:25
Sub Approved Pobr. Zatwierdził		Weight Ciężar	kg
Sub Contractor Podwykonawca		Sub Contractor Dwg No. Nr rys. poddostawcy	
Sub Checked Pobr. Sprawdził	SKN	KKS Dwg. No. Nr rys. Dwg. KKS	
Sub Approved Pobr. Zatwierdził	ADK		953-FWHBC...-MTC5114

PLOT DATE, TIME: 21.12.2011 09:28